

SEZIONE A-A  
SCALA 4 : 5

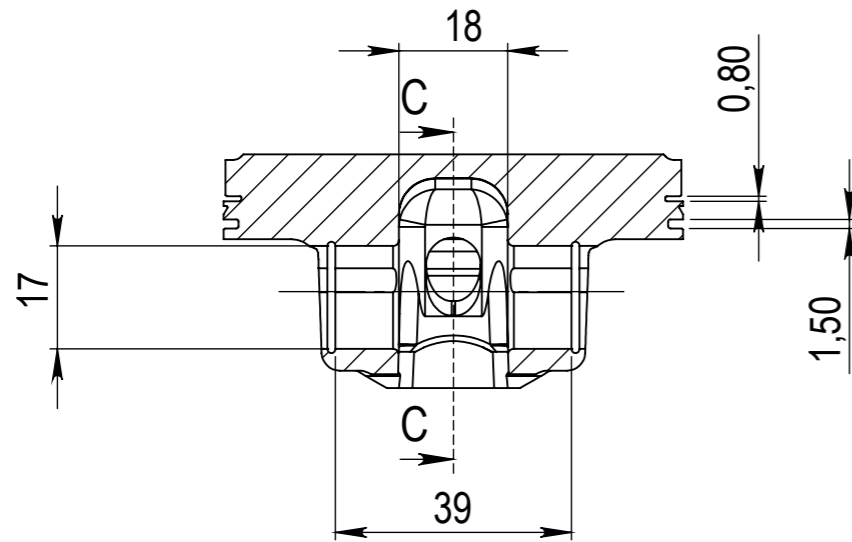

SEZIONE B-B

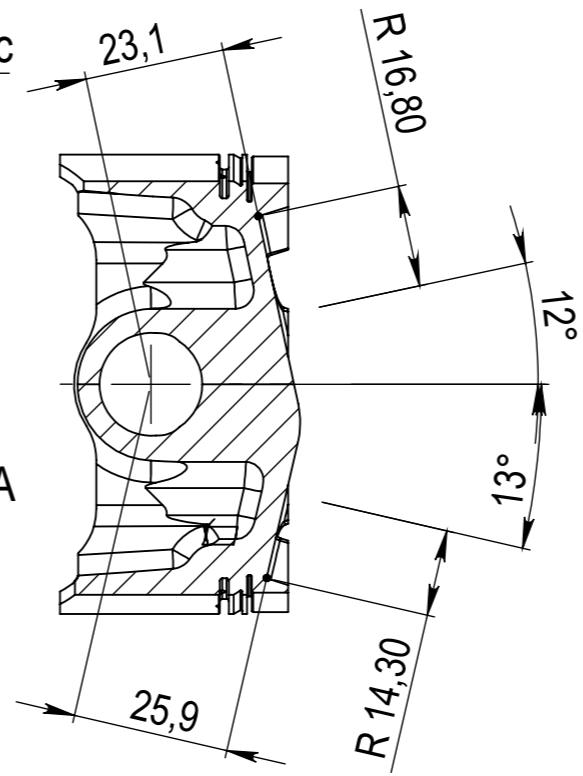
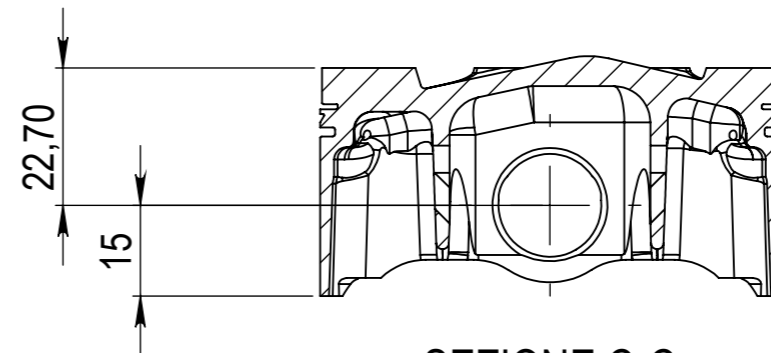

SEZIONE C-C

Diametro cilindro Cylinder bore	Codice commerciale Commercial code	Peso Pistone Completo (g) Complete Piston Weight (g)			Note - Notes	
∅ 76.00 mm	1207A000	202.5 +5				
			UFFICIO TECNICO	Denominazione Type	Norme applicabili Specification	
			Dis.re Draftman A. Piano	Kawasaki ZX R 1000 MY13		
			Controllato Controller G. Casolari	Impiego Use Cylinder ∅ 76.00 mm	N. Cilindri No. Cylinder 4	
			Scala Scale Free	Data Date 15.10.18	Codice Disegno Drawing Code 1354.7600	Indice Modifica Draw Index 01
					Materiale Material 2618A-T6	Durezza Hardness 75 ±5 HRB
Disegno eseguito con CAD. Vietato modificare manualmente.				This is a CAD drawing. No manual alterations.		