

A1 INSTALLATION DRAWING

IF THIS DOCUMENT IS PRINTED IN HARDCOPY, IT IS FOR INFORMATION USE ONLY AND THEREFORE IS NOT SUBJECT TO UPDATING CONTROLS. ALWAYS REFER TO SOLIDWORKS VIEWER FOR LATEST ISSUE



THIS DRAWING IS CONFIDENTIAL AND IS SUPPLIED ON THE EXPRESS CONDITION THAT IT SHALL NOT BE LOANED OR COPIED OR DISCLOSED TO ANY OTHER PERSON OR USED FOR ANY OTHER PURPOSE WITHOUT THE WRITTEN CONSENT OF AP RACING LTD.



AP Racing
Wheler Road
Coventry
CV3 4LB

Tel: +44 (0) 24 7663 9595
Fax: +44 (0) 24 7663 9559
e-mail: engineering@apracings.co.uk
Web site: http://www.apracings.com

© AP Racing Ltd. 2005

Issue No.	Alterations			Zone	Initials
	Date & No.	Particulars	#		
5	24/02/05 C2626	REDRAWN IN SOLIDWORKS CP3457-19 ADDED.	#	JG	
6	04/12/09	CP3457-23 ADDED.	#	JG	
7	26/05/10	CP3457-22 ADDED.	#	AB	
8	05/01/11	REDRAWN ON AN A1 DRAWING SHEET. CP3457-24 ADDED.	#	JG	
9	05/04/13 C4477	CP3457-26 ADDED	#	JG	
10	24/02/05 C2626	CP3457-26 MOVED TO 'HIGH SPEED RELEASE BEARING INNER RACE ROTATES'	#	JG	
11	04/06/18 CS263	CP3457-12 ADDED	#	AC	

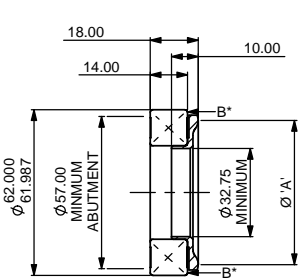

HIGH SPEED RELEASE BEARING
INNER RACE ROTATES

Ø 'A' RELEASE FULCRUM	PART NUMBER
Ø45.00mm	CP3457-26
Ø50.00mm	CP3457-11
Ø54.00mm	CP3457-6
Ø38.00mm	CP3457-16

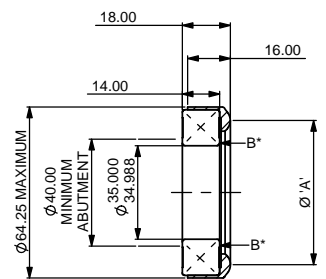

STANDARD RELEASE BEARING
(Ø35.00mm LOCATION DIAMETER)
OUTER RACE ROTATES

Ø 'A' RELEASE FULCRUM	PART NUMBER
Ø50.00mm	CP3457-1
Ø54.00mm	CP3457-2

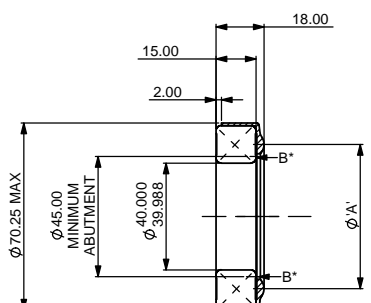

STANDARD RELEASE BEARING
(Ø40.00mm LOCATION DIAMETER)
OUTER RACE ROTATES

Ø 'A' RELEASE FULCRUM	PART NUMBER
Ø50.00mm	CP3457-9
Ø54.00mm	CP3457-10
Ø45.00mm	CP3457-19

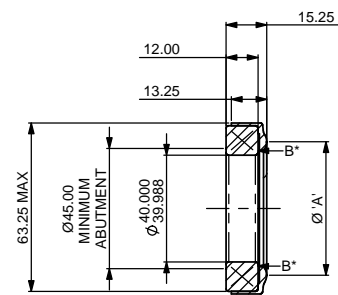

REDUCED THICKNESS BEARING
(Ø40.00 LOCATION DIAMETER)
OUTER RACE ROTATES

Ø 'A' RELEASE FULCRUM	PART NUMBER
Ø54.00mm	CP3457-27
Ø50.00mm	CP3457-24

INSTALLATION OF RELEASE BEARING.

TO PREVENT INTERNAL DAMAGE TO BALL RACES WHEN INSTALLING ON THE RELEASE MECHANISM, USE THE MINIMUM FORCE NECESSARY ON SURFACES MARKED 'B' ONLY.

NOTE:

THE FOLLOWING BEARING ASSEMBLIES ARE FILLED WITH KLUBER ASONIC HQ72-102 GREASE
CP3457-1, -2, -6, -11, -16.

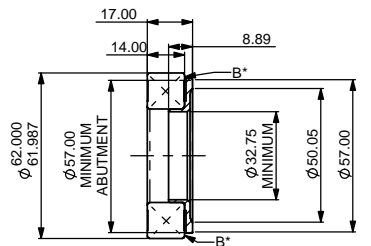

HIGH SPEED RELEASE BEARING
INNER RACE ROTATES

RELEASE FULCRUM	PART NUMBER
FLAT	CP3457-22

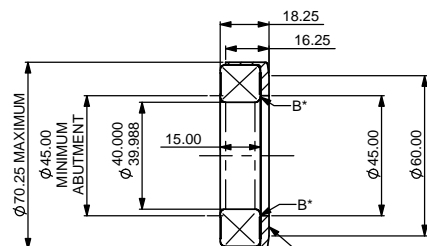

STANDARD RELEASE BEARING
(Ø40.00mm LOCATION DIAMETER)
OUTER RACE ROTATES

RELEASE FULCRUM	PART NUMBER
FLAT	CP3457-23

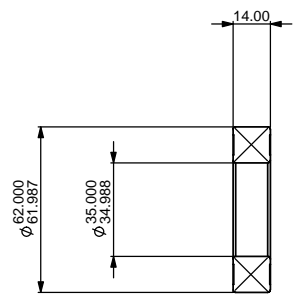

RELEASE FULCRUM	PART NUMBER
NONE	CP3457-12

SCALE 1:1	SHEET 1 OF 1
DRAWN	Jeremy Govan
APPROVED	
DERIVED FROM	
TITLE	RELEASE BEARING ASSEMBLY INSTALLATION DRAWING
DRG NO.	CP3457-7