



**ABYT, ABYT-V**  
Spherical Bearings - Self-Lubricating  
High Misalignment

Temperature: Operating temperature range -65° to 250°F (-54° to 121°C). Broader temperature capabilities are achievable.

Options: Bearings with CRES 17-4PH races will be designated by "H" suffix.  
(Example: ABYT8VH)

Qualification: Liner approved to MIL-B-8942

**MATERIALS**

Part No.	Ball	Race	Liner
Catalog No.	CRES 440C AMS 5630, RC 55-62	CRES 410 AMS 5613, RC 23-35	*Teflon/Fabric Bonded to race I.D. No. Lub. Required

NMB Part Number Chamfered V-Grooved		(B) Bore Diameter		(D) Outside Diameter		(W) Ball Width		(H) Race Width		(O) Shoulder Diameter		Ball Diameter		(C) Race Chamfered × 45°		(Q) Misalign- ment
		Inch	mm	Inch	mm	Inch	mm	Inch	mm	Inch	mm	Inch	mm	Inch	mm	
		+ .0000	+0.000	+ .0000	+0.000	+ .000	+0.00	+ .005	+0.13	Ref.	Ref.	Ref.	Ref.	+ .000	+0.00	Ref.
		- .0005	-0.013	- .0005	-0.013	- .005	-0.13	- .005	-0.13	Ref.	Ref.	Ref.	Ref.	- .010	-0.25	Ref.
ABYT3	ABYT3V	.1900	4.826	.5625	14.288	.500	12.70	0.210	5.33	.319	8.10	.437	11.10	.020	0.51	15°
ABYT4	ABYT4V	.2500	6.350	.7400	18.796	.593	15.06	0.255	6.48	.390	9.91	.593	15.06	.022	0.56	24°
ABYT5	ABYT5V	.3125	7.938	.6875	17.462	.625	15.88	0.255	6.48	.418	10.62	.593	15.06	.022	0.56	20°
ABYT6	ABYT6V	.3750	9.525	.9060	23.012	.813	20.65	0.345	8.76	.512	13.00	.781	19.84	.032	0.81	23°
ABYT7	ABYT7V	.4375	11.112	1.0000	25.400	.875	22.22	0.345	8.76	.618	15.70	.875	22.22	.032	0.81	22°
ABYT8	ABYT8V	.5000	12.700	1.1250	28.575	.937	23.80	0.401	10.19	.730	18.54	1.000	25.40	.032	0.81	20°
ABYT10	ABYT10V	.6250	15.875	1.3750	34.925	1.200	30.48	0.567	14.40	.856	21.74	1.250	31.75	.032	0.81	20°
ABYT12	ABYT12V	.7500	19.050	1.5625	39.688	1.280	32.51	0.620	15.75	.970	24.64	1.375	34.92	.044	1.12	18°
ABYT14	ABYT14V	.8750	22.225	1.7500	44.450	1.400	35.56	0.625	15.88	1.140	28.96	1.531	38.89	.044	1.12	18°
ABYT16	ABYT16V	1.0000	25.400	2.1250	53.975	1.875	47.62	0.835	21.21	1.278	32.46	1.875	47.62	.044	1.12	21°
ABYT20	ABYT20V	1.2500	31.750	2.5000	63.500	1.875	47.62	1.005	25.53	1.523	38.68	2.250	57.15	.044	1.12	21°
ABYT24	ABYT24V	1.5000	38.100	3.0000	76.200	2.250	57.15	1.175	29.84	1.800	45.72	2.672	67.87	.044	1.12	21°

\* A trade name of E.I. duPont de Nemours & Co., Inc.

#The load ratings listed for this series of bearings do not take into account pin deflection. Excess pin deflection can cause a crack to traverse the ball sphere. (See page 24).

See next sheet for further information

The information contained in this data sheet represents typical performance of the product, and is subject to change without notice. Product performance may be varied or enhanced to meet individual requirements. For further information please contact your local sales office



Rose Bearings Ltd., Lincoln Pl. Doddington Road, Lincoln, Lincolnshire LN63RA, England Tel: (44) 1522300933 Fax: (44) 1522300976  
 NMB Minebea GmbH, Siemenstrasse 30, 63225 Langen, Germany Tel: (49) 6103-913-0 Fax: (49) 6103-913-220  
 NMB Minebea S.r.l., 5 Av. Des Bosquets, 9550 Baillieten France, France Tel: (33) 1-34083939 Fax: (33) 1-34083930  
 NMB Italy Srl, Via A Grandi 39/41, 20017 Mazzo di Rho, Milan Italy Tel: (39) 2-939711 Fax: (39) 2-93901154  
 NMB Technologies Inc., 9730 Independence Avenue, Chatsworth, California USA Tel: (818) 341 3355 Fax: (818) 3418207  
 Minebea Technologies Pte. Ltd. PSA Building, 460 Alexandra Road, #34-02, Singapore 119963 Tel: (65) 278 8522 Fax: (65) 4446527

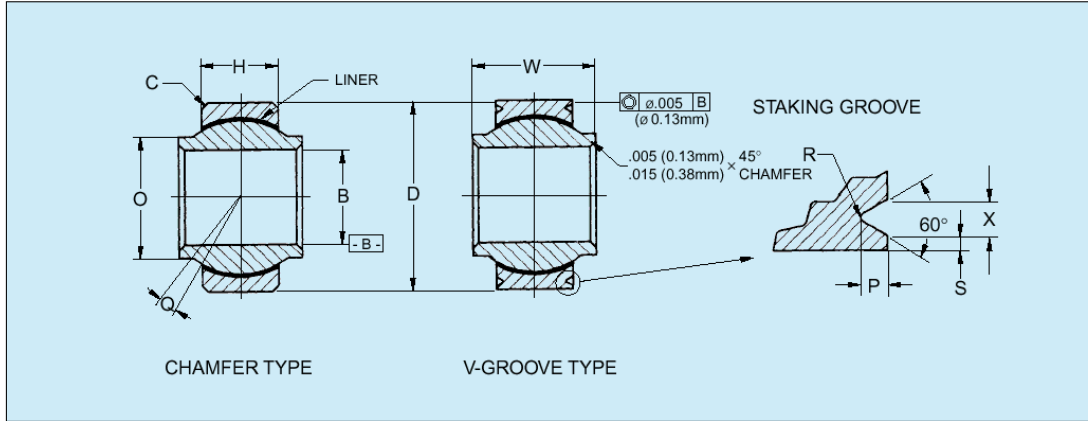

Staking Groove Data				No Load Rotational Breakaway Torque		Static Limit Load		Dynamic Osc. Radial Load		Approx. Weight							
(P)		(R)		(S)		(X)											
Inch	mm	Inch	mm	Inch	mm	Inch	mm	In-lb	N-m	lbs	N	lbs	N	lbs	N	lbs	kg
+0.000	+0.00	+0.000	+0.00	+0.000	+0.00	+0.000	+0.00										
-0.015	-0.38	-0.010	-0.25	-0.010	-0.25	-0.010	-0.25										
.030	0.76	.015	0.38	.020	0.51	.045	1.14	5-5.0	0.06-0.56	4100	18238	350	1557	2100	9341	.018	0.008
.030	0.76	.015	0.38	.020	0.51	.045	1.14	1.0-5.0	0.11-0.56	7100	31581	450	2002	3800	16902	.036	0.016
.030	0.76	.015	0.38	.020	0.51	.045	1.14	1.0-5.0	0.11-0.56	9000	40032	450	2002	3800	16902	.029	0.013
.030	0.76	.015	0.38	.020	0.51	.045	1.14	1.0-5.0	0.11-0.56	16000	71168	2000	8896	7200	32026	.068	0.031
.030	0.76	.015	0.38	.020	0.51	.045	1.14	1.0-5.0	0.11-0.56	19300	85846	2000	8896	8100	36029	.095	0.043
.030	0.76	.015	0.38	.020	0.51	.045	1.14	1.0-5.0	0.11-0.56	26100	116093	3200	14234	10900	48483	.159	0.072
.040	1.02	.020	0.51	.030	0.76	.055	1.40	1.0-5.0	0.11-0.56	44500	197936	7000	31136	20000	88960	.245	0.111
.060	1.52	.020	0.51	.030	0.76	.080	2.03	1.0-5.0	0.11-0.56	54800	243750	8700	38698	24200	107642	.315	0.143
.060	1.52	.020	0.51	.030	0.76	.080	2.03	2.0-8.0	0.23-0.90	65800	292678	8850	39365	27600	122765	.430	0.195
.060	1.52	.020	0.51	.030	0.76	.080	2.03	2.0-8.0	0.23-0.90	108000	480384	15900	70723	45600	202829	.831	0.377
.060	1.52	.020	0.51	.030	0.76	.080	2.03	3.0-15.0	0.34-1.70	158000	702784	23000	102304	66600	296237	1.318	0.598
.060	1.52	.020	0.51	.030	0.76	.080	2.03	3.0-15.0	0.34-1.70	220000	978560	32000	142336	93200	414554	2.223	1.008

The information on this sheet is a continuation of the data on the previous sheet to cross reference the data, place two sheets next to each other