

- INSTALLATION NOTES:**
1. USE ONLY WITH DOT-3 OR DOT-4 BRAKE FLUID.
 2. NO INTERNAL TRAVEL LIMITER. MUST BE USED WITH CLUTCH PEDAL STOP.
 3. SEAL REBUILD KIT = 62-905.
 4. SEAL INSTALLATION TOOL = 96-002.
 5. HYDRAULIC AREA = 1.215 SQ IN.
 6. EITHER PORT MAY BE USED FOR FEED OR BLEED.
 7. ORIENTATE BLEED PORT TO WITHIN 10 DEGREES OF TOP CENTER TO FACILITATE BLEEDING PROCESS.
 8. UNIT IS SHIPPED WITH SHIM 62-903 (.050" THICK) INSTALLED UNDER THE BEARING WHICH MAY BE REMOVED FOR ADDITIONAL CLEARANCE.
 9. BOTH PORTS 3/8-24 UNF X .28 THREAD DEPTH.

ITEM	PART NUMBER	DESCRIPTION	QTY
1	62-1503	HYDRAULIC BASE	1
2	62-617	WIPER	1
3	62-614	HYDRAULIC SEAL	1
4	73-820	FITTING, AN-3	2
5	SEE CHART	PISTON	1
6	62-008	BEARING	1
7	62-903	SHIM	1

This document contains proprietary information of TILTON ENGINEERING, INC., and its receipt or possession does not convey the rights to reproduce, disclose its contents, or to manufacture, use or sell anything it may describe. Reproduction, disclosure, or use without specific written authorization of TILTON ENGINEERING, INC. is strictly forbidden.

TILTON ENGINEERING, INC.

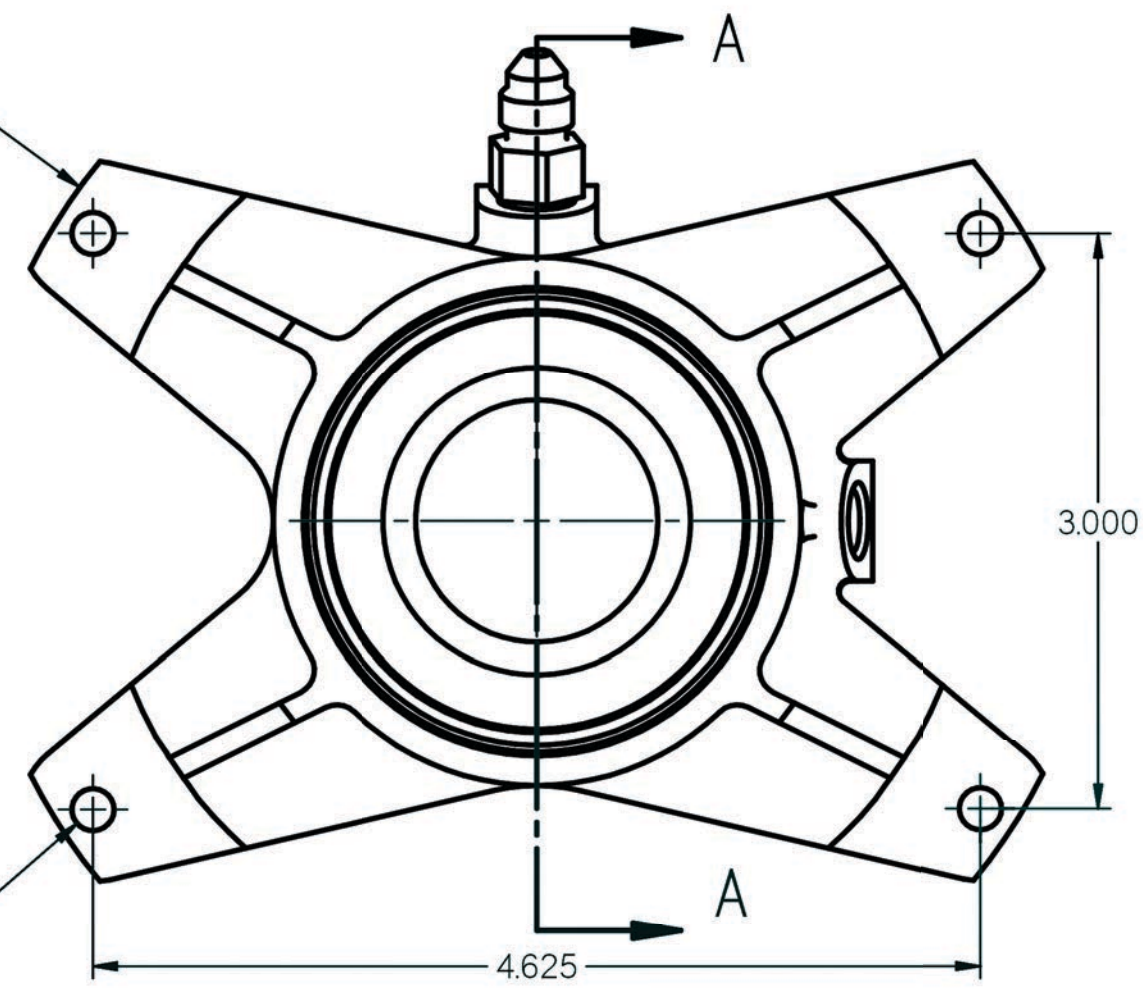
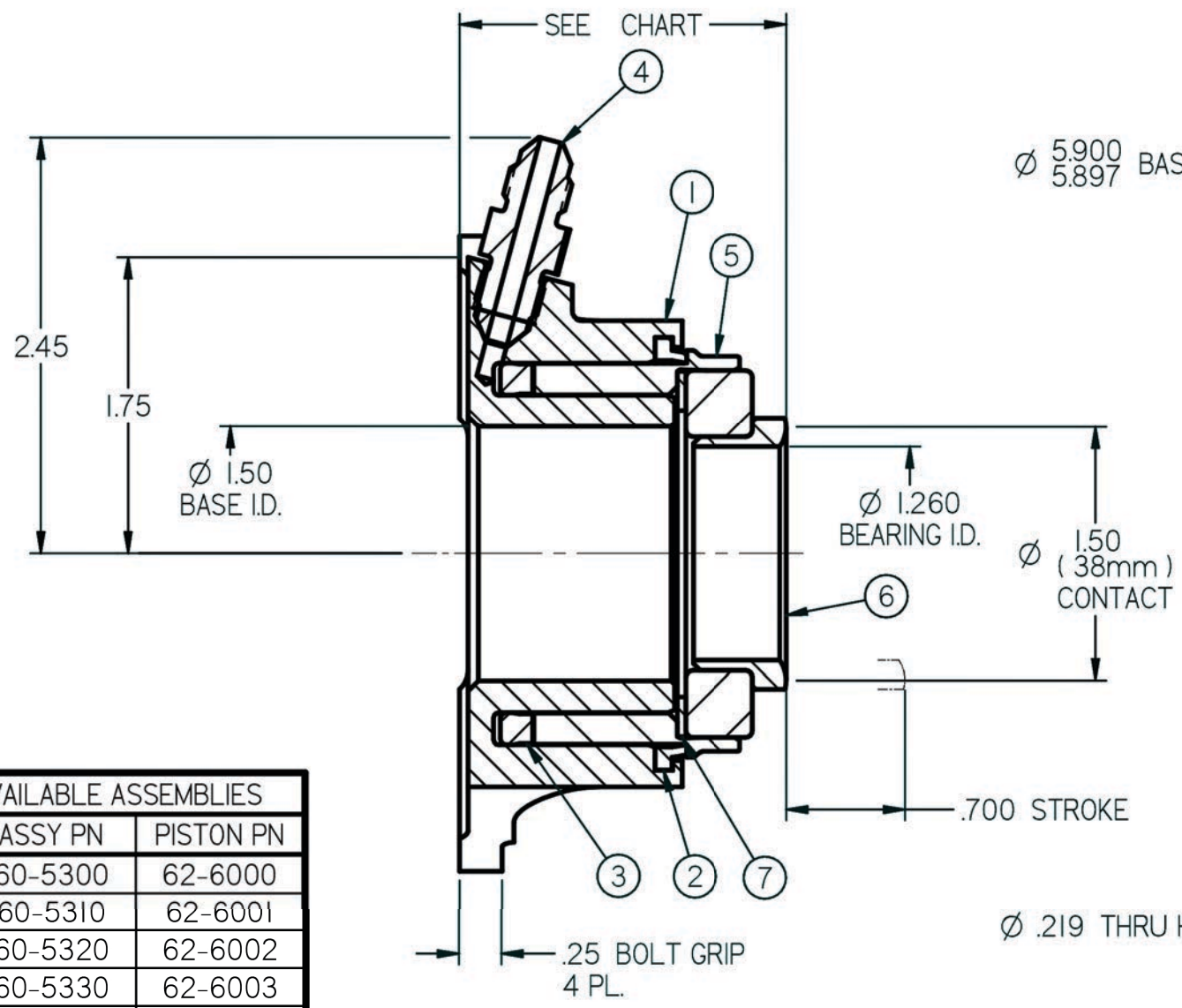

HEIGHT	ASSY PN	PISTON PN
1.87-1.92*	60-5300	62-6000
1.97-2.02*	60-5310	62-6001
2.07-2.12*	60-5320	62-6002
2.17-2.22*	60-5330	62-6003
2.27-2.32*	60-5340	62-6004
2.37-2.42*	60-5350	62-6005
2.47-2.52*	60-5360	62-6006
2.57-2.62*	60-5370	62-6007
2.67-2.72*	60-5380	62-6008
2.77-2.82*	60-5390	62-6009

SECTION A-A

* HEIGHTS SHOWN IN CHART ARE WITH AND WITHOUT 62-903 SHIM

TILTON ENGINEERING, INC.		FAX 805/688-2745	
25 EASY STREET, P.O. BOX 1787, BUELLTON, CA 93427 805/688-2353			
TITLE: HYDRAULIC RELEASE BEARING ASSEMBLY 38 mm RADIUS FACED BEARING, TILTON BELLHOUSING MNT			
DRAWN BY WAHL	CHKD LUND	SCALE 1:1	SIZE DWG
P/N SEE CHART	DATE 03/22/2012	SHEET 1 OF 1	B 5612
			REV NC